



Qualcomm Technologies, Inc.

Qualcomm[®] Robotics RB3 Platform

Linux Embedded Quick Start Guide

Rev. A

February 15, 2019

All Qualcomm products mentioned herein are products of Qualcomm Technologies, Inc. and/or its subsidiaries.

Qualcomm and Hexagon are trademarks of Qualcomm Incorporated, registered in the United States and other countries. Other product and brand names may be trademarks or registered trademarks of their respective owners.

This technical data may be subject to U.S. and international export, re-export, or transfer ("export") laws. Diversion contrary to U.S. and international law is strictly prohibited.

Qualcomm Technologies, Inc.
5775 Morehouse Drive
San Diego, CA 92121
U.S.A.

Revision history

| Revision | Date | Description |
|----------|---------------|-----------------|
| A | February 2019 | Initial release |

Contents

- 1 Qualcomm Robotics RB3 Platform 4**
 - 1.1 Required equipment.....4
- 2 Board views..... 5**
- 3 Start the board 6**
- 4 Program system images with Fastboot..... 7**

1 Qualcomm Robotics RB3 Platform

The Qualcomm® Robotics RB3 Platform is a dedicated platform designed to accelerate computing and intelligence capabilities for consumer and industrial robotics.

The platform supports development of smart, power-efficient, cost-effective robots by combining high-performance heterogeneous computing, Qualcomm® Artificial Intelligence (AI) Engine for on-device machine learning, computer vision, voice interface, multimedia and connectivity.

This quick start guide provides details on required equipment, board views, starting the board, and programming system images.

1.1 Required equipment

Required

| Equipment | Description |
|----------------------------------------------|-----------------------------------------------------------|
| Robotics DragonBoard™ 845c development board | Based on the Qualcomm® SDA845 processor |
| Power adapter | 12V with 2500mA required by the 96Boards specification |
| USB to Micro USB cable | For serial console interface and ADB, Fastboot commands |
| USB to USB Type C cable | For connecting the USB3.0 Type C port and flashing images |
| Host PC | For connecting the board and installing Fastboot |

Optional

| Equipment | Description |
|---------------------------------------|--------------------------------------------------------------------------------------------------------------------------------------|
| Navigation Mezzanine board | Allows the addition of cameras and peripherals and enhances onboard components |
| Camera modules | <ul style="list-style-type: none">▪ Main Camera▪ Tracking Camera▪ ToF Camera▪ Stereo Camera |
| Machine Communication Mezzanine board | Supports the LTE module for improved communication |

2 Board views

Top view

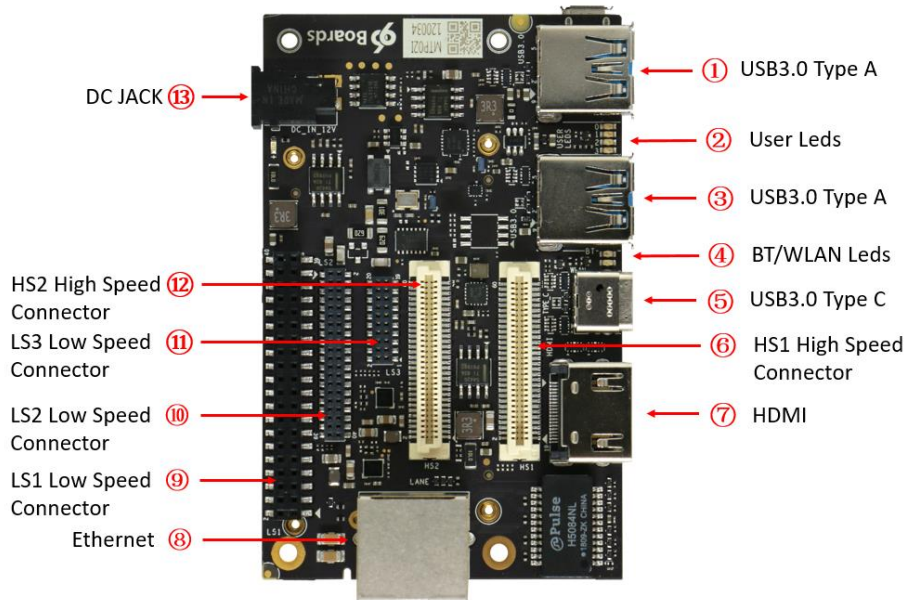

Back view

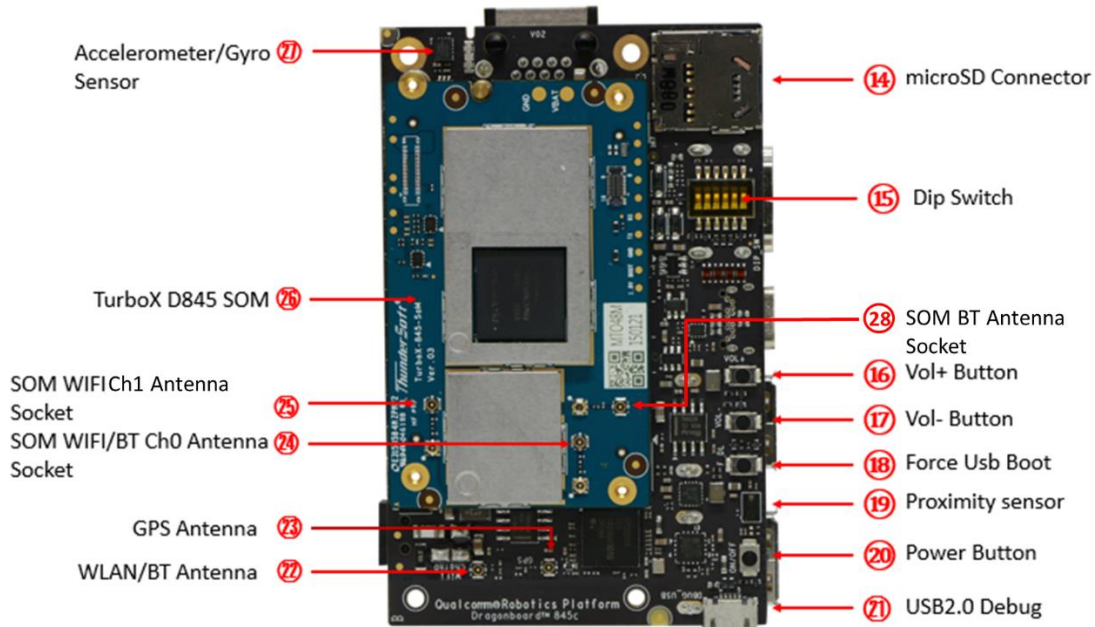

3 Power on the Robotics DragonBoard

1. Open the serial console tool on the host PC (for example: minicom).
2. Turn on SW2 on the Dip Switch (see Back view, #15) to enable the USB2.0 debug port (see Back view, #21).
3. Turn on SW3 on the Dip Switch (see Back view, #15) to enable the auto power up on USB-C cable connection(along with power connector).

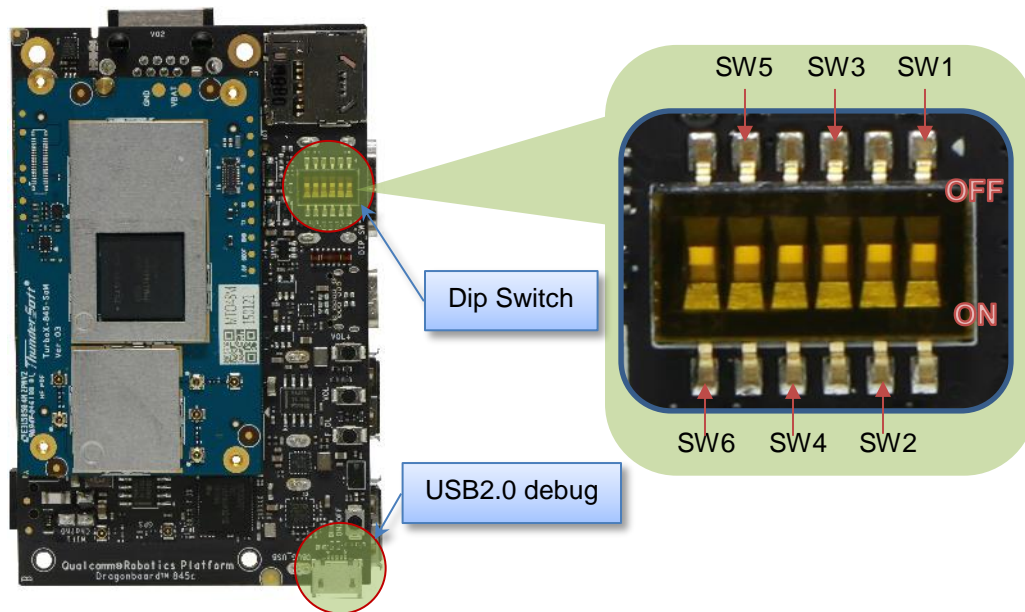

4. Connect the USB cable Micro-B plug to the USB2.0 debug port (see Back view, #21). and connect the other end to an available USB port on the host PC.

NOTE: Set the Bps/Par/Bits to 115200 8N1

5. Connect the power supply to power connector (see Top view, #13).
6. Plug the power supply into a power outlet. The green power-up LED should illuminate.
7. Press and release the power button on the device. The yellow user LED0 should illuminate.
8. The board will start the booting process. Login credentials will display on the host PC:

```
sda845 login: root
```

```
Password: 123456
```

For more information and support, see:

- *Qualcomm Robotics RB3 Platform Hardware User Guide*
- *Qualcomm Robotics RB3 Platform Linux User Guide*

4 Program system images with Fastboot

1. Download the Linux images package from the Thundercomm website and unzip to the SDA845-ROBOT-IMAGE.

| | | | | |
|------------------------------|--------------------------------------------------------------|---------------------------------------------------------------------|-----------------------------------------------------------------|--------------------------|
| Introduction | Specifications | Technical Documents | FAQ | Purchase |
| Documentation | Hardware | Quick Start Guide | | |
| | | Robotics DragonBoard 845c Spec | | |
| | | Robotics Navigation Mezzanine Spec | | |
| | | Robotics Machine Communication Mezzanine Spec | | |
| | | Main Camera Spec | | |
| | | Tracking Camera Spec | | |
| | | ToF Camera Hardware User Guide | | |
| | | SLM Camera Hardware User Guide | | |
| | | Qualcomm Robotics RB3 Platform Hardware User Manual | | |
| | | Qualcomm Robotics RB3 Platform Schematics.pdf | | |
| | | Qualcomm Robotics RB3 Platform 3D STEP Models | | |
| | | D845 SOM Datasheet | | |
| | | D845 SOM GPIO Pin Assignment | | |
| | | Software | Qualcomm Robotics RB3 Platform Linux User Guide | |
| | Qualcomm Robotics RB3 Platform Release notes | | | |
| | SLM Camera ImageViewer.pdf | | | |
| Firmware | Qualcomm Robotics RB3 Platform Image | | | |

2. Entering to FastBoot
 - a. Remove the usb C cable if connected. Plug in the power supply, press and hold **VOL -** then press **Power** button once quickly to force the device to enter Fastboot mode
 - b. Alternatively if device is in adb mode, connect usb type c and use “adb reboot bootloader” from the command prompt
3. Plug the USB cable into the Device Type C port.

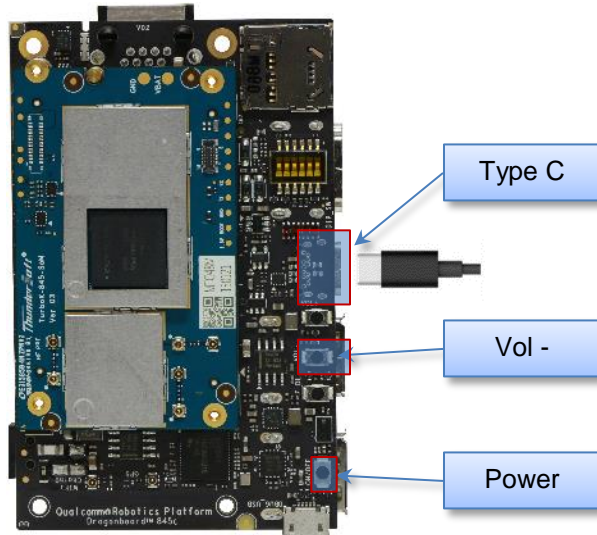

4. Confirm that Fastboot is active as follows:

a. From the Windows command shell, run:

```
$fastboot devices  
dae93bbb fastboot
```

b. From Linux, run:

```
$ sudo fastboot devices  
dae93bbb fastboot
```

5. Flash images:

a. From the Windows command shell, run:

```
$ flash_all.bat
```

b. From Linux, run:

```
$ sudo flash_all.sh
```

6. After the script is executed, the board will reboot automatically .